

Bulletin  
783.05-3NE  
January 2016

# NOR'EAST™

## CONTROLS



## THREE WAY VALVES - MIXING

### SERIES 8300 MODEL 8305



Previously manufactured by  
Dezurik® and Honeywell®

## Description:

Nor'East Series 8300 3-Way Brass globe valves are designed for light duty, mixing applications. These valves are available in 1/2 through 2-inch sizes screwed ends. The spring-type pneumatic diaphragm actuator is available as either direct or reverse action as specified. Figure 1 shows the flow direction in mixing applications.

## Accessories:

- Top-mounted handwheel (direct-acting actuator)
- Side-mounted positioners
- Micro Switch precision switches
- Solenoids
- Air sets

## Actuator

<b>Type</b>	Pneumatic, diaphragm-actuated type 05. Direct or reverse acting.
<b>Construction</b>	Cast aluminum diaphragm cases and yoke.
<b>Diaphragm Material</b>	Molded of flexible Neoprene and convoluted to retain a constant effective area through the total stroke. Ambient temperature range of -29° to 71°C (-21° to -160°F).
<b>Effective Diaphragm Material</b>	Direct acting: 40 in <sup>2</sup> (258 cm <sup>2</sup> ) Reverse acting: 38 in <sup>2</sup> (245 cm <sup>2</sup> )
<b>Actuator Stem</b>	Zinc-plated steel.
<b>Spring</b>	Totally enclosed and corrosion resistant. Ranges: 3 to 15 psig standard. (For other ranges, see Table 2)
<b>Air Pressure (Air-to-diaphragm)</b>	Normal: 18 or 26 psig (124 or 172 kPa). Maximum: 35 psig (241 kPa) for reverse acting, 50 psig (345 kPa) for direct acting.
<b>Air Connections</b>	1/4" NPT.

## Body

<b>Type</b>	Three-way, globe-type body for mixing service.
<b>Material</b>	Brass
<b>Sizes</b>	Screwed end: 1/2, 3/4, 1, 1 1/4, 1 1/2 and 2 inch.
<b>Ratings</b>	150 psi

## Bonnet

<b>Type</b>	Plain: For process temperatures between 40° and 250°F (4.4 and 121°C)
<b>Packing</b>	Spring-loaded, carbon fiber reinforced PTFE V-rings.

## Trim

<b>Material</b>	Brass
<b>Plug</b>	Linear contour plug stem-guided for throttling or two position (on-off) control.
<b>Valve Travel</b>	3/4 inch (19mm).
<b>Leakage</b>	Maximum allowable leakage under factory testing is 0.01% of rated Cv.
<b>Sizing Data</b>	(see Tables 1 and 2)
<b>Dimensions</b>	(see Table 3 and Figure 2)

## ORDERING DATA

### Please Specify:

- Valve Model 8305
- Size
- Spring Range
- Air-to-Open or Air-to-Close
- Accessories

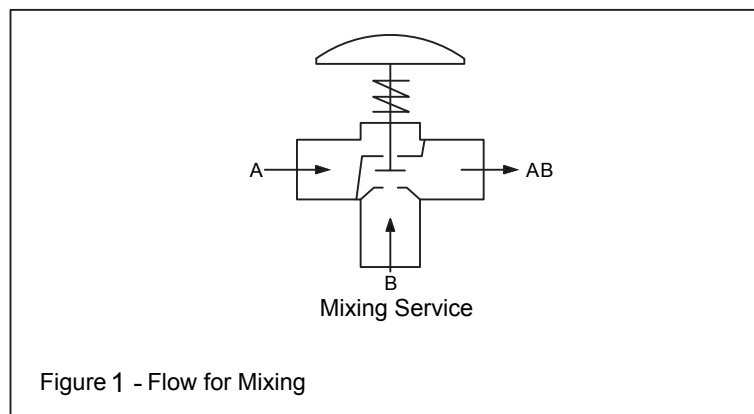

**Table 1 - Flow Coefficient Cv**

Plug	Nominal Valve Size (inches)					
	1/2	3/4	1	1 1/4	1 1/2	2
Linear Contour	4.7	7.3	11.7	18.7	29.3	46.3

**Table 2 - Maximum Pressure Differentials in Closed Positions**

Service	Control	Air Supply Psig	Spring Range Psig	Valve Size (inches)					
				1/2	3/4	1	1 1/4	1 1/2	2
Mixing	Throttling or On-Off	18	3 - 15, 3 - 9, 9 - 15	50	50	50	50	35	15
		25	3 - 15, 3 - 9	50	50	50	50	35	15
			9 - 15	50	50	50	50	50	50

**Table 3 - Dimensions**

Valve Size	A	B	C	D
1/2	3-1/4" (83mm)	12-7/8" (327mm)	1-9/16" (39.7mm)	2-9/16" (65mm)
3/4	3-1/4" (83mm)	12-7/8" (327mm)	1-9/16" (39.7mm)	2-9/16" (65mm)
1	4-1/16" (103mm)	12-7/8" (327mm)	1-9/16" (39.7mm)	2-5/8" (66.5mm)
1 1/4	4-3/16" (106mm)	12-7/8" (327mm)	1-9/16" (39.7mm)	2-7/8" (72.5mm)
1 1/2	4-3/4" (120mm)	13-1/8" (333mm)	1-13/16" (46.5mm)	3" (77mm)
2	5-1/4" (134mm)	13-1/8" (333mm)	1-13/16" (46.5mm)	3-5/16" (83.5mm)

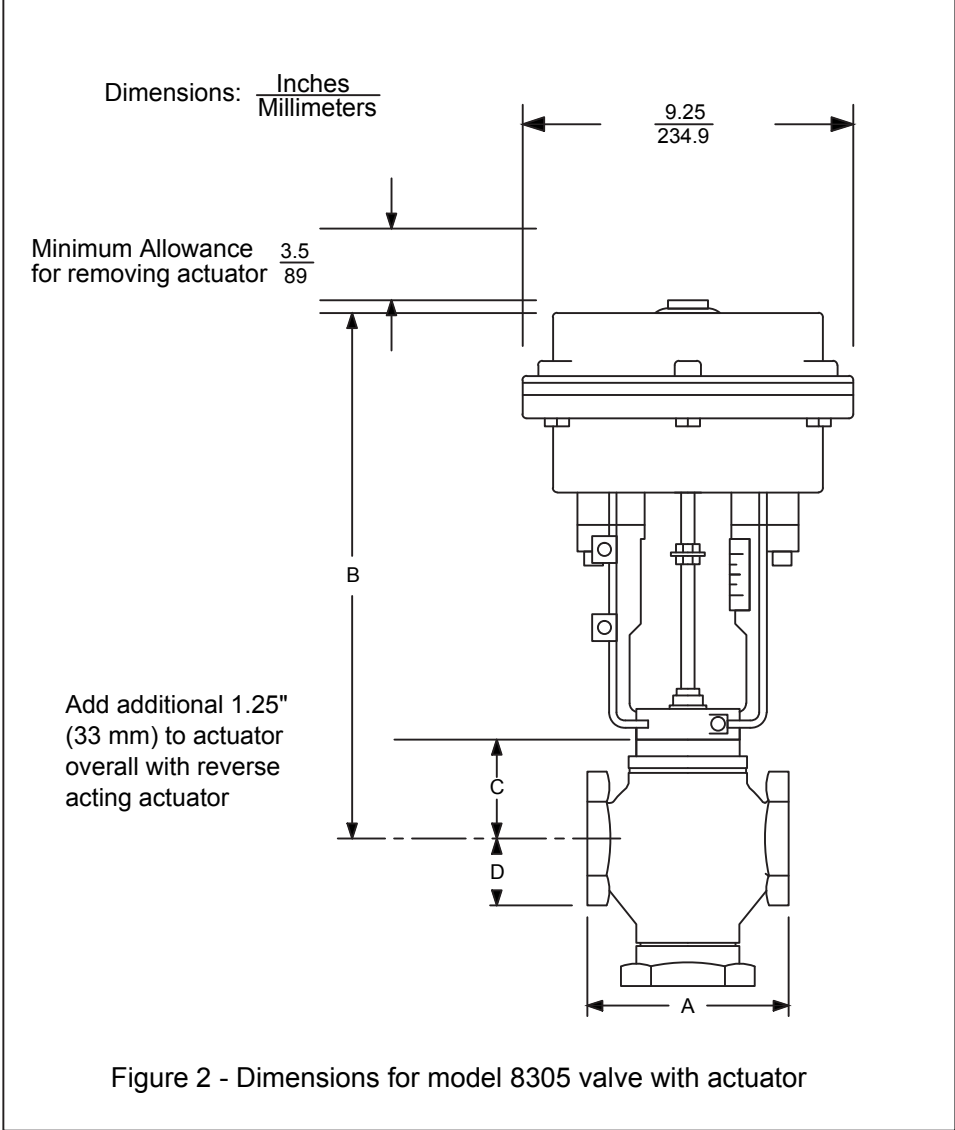

**NOTES:**

**NOTES:**

## Guarantee

Products, auxiliaries and parts thereof, of Allagash International Group, LLC, a manufacturer of Nor' East Controls, are guaranteed for a period of one year from the date of shipment against defective workmanship and material only, when properly installed, operated and serviced in accordance with Allagash International Group, LLC recommendations. Replacement for items of Allagash International Group, LLC manufacture will be made free of charge if proved to be defective within such time. No claim for special or consequential damages, transportation, or labor shall be allowed. Purchaser shall be solely responsible for determining suitability for use and in no event shall Allagash International Group, LLC be liable in this respect. Equipment or parts manufactured by others but furnished by Allagash International Group, LLC will be repaired or replaced, only to the extent provided in the original manufacturer's warranty to Allagash International Group, LLC. Allagash International Group, LLC does not guarantee resistance to corrosion, erosion, abrasion or other sources of failure, nor does Allagash International Group, LLC guarantee a minimum length of service. Failure of the purchaser to give prompt written notice of any alleged defect under this guarantee forthwith upon its discovery, or use and possession thereof after an attempt has been made and completed by someone other than Allagash International Group, LLC or an authorized representative to remedy defects therein, or failure to return products or parts for replacement as herein provided, of failure to install, operate, and maintain said products or parts according to instructions provided by Allagash International Group, LLC, of failure to pay the entire contract price when due, shall be a waiver of all rights under these representations.

The foregoing guarantee shall be null and void, if, after shipment from our factory, the item is modified in any way or component of another manufacturer, such as but not limited to; an actuator is attached to the item by valves & controls other than a Allagash International Group, LLC.

Factory Service Personnel. All orders accepted shall be deemed accepted subject to this guarantee, which shall be exclusive of any other previous guarantee, and this shall be the only effective guarantee or warranty binding on Allagash International Group, LLC, anything to the contrary contained in the purchase order, or represented by any agent or employee of Allagash International Group, LLC, in writing or otherwise, notwithstanding, including but not limited to implied warranties.

THE FOREGOING OBLIGATIONS ARE IN LIEU OF ALL OTHER OBLIGATIONS AND LIABILITIES INCLUDING WARRANTIES OF FITNESS OR MERCHANTABILITY OR OTHERWISE, EXPRESSED OR IMPLIED IN FACT OR BY LAW, AND STATE NOR'EAST CONTROLS AND EXCLUSIVE LIABILITY AND PURCHASER'S EXCLUSIVE REMEDY FOR ANY CLAIM IN CONNECTION WITH THIS SALE OR FURNISHING OF SERVICES, GOODS, OR PARTS, THEIR OWN DESIGN, SUITABILITY FOR USE, INSTALLATION OR OPERATION.

## Limitation of Liability

In no event shall Allagash International Group, LLC, a Manufacturer of Nor' East Controls be liable for any direct, indirect, special or consequential damages whatsoever, and Allagash International Group, LLC liability, under no circumstances, will exceed the contract price for the goods and/or services for which liability is claimed. Any action for breach of contract must be commenced within 1 year after the cause of the action has occurred.



70 Ingersoll Drive, Portland ME 04103 . phone 207-781-8831 . fax 207-781-8830

**ALLAGASHINTERNATIONAL.COM**

## Sales and Service

Allagash International Group, LLC representatives are located in major cities throughout the world. For the name of the representative nearest you, email us: [sales@allagashinternational.com](mailto:sales@allagashinternational.com)

Allagash International, Group LLC reserves the right to incorporate our latest design and material changes without notice or obligation. Design features, materials of construction and dimensional data, as described in this bulletin, are provided for your information only and should not be relied upon unless confirmed in writing by Allagash International, Group LLC. Certified drawings are available upon request.