

Type 05 Air-O-Motor Actuators



Function

Type 01 Air-O-Motor actuators, thrust or lever type (Figures 1 and 2), are power devices which operate on a small air signal from a controller and convert this signal into mechanical motion.

The force developed exerts a straight, downward thrust, or operates a reversible lever working on a pivot. These actions operate final control elements such as rotary shaft valves, dampers, louvers, and butterfly valves.

Description

Both thrust and lever model have steel diaphragm cases, cast iron spring barriers, and cast iron yokes. The Air-O-Motor actuator diaphragms are Buna-N with a nylon insert. The actuator stem is zinc-plated steel.

Thrust Model

This model has direct action, air pressure pushes down on the stem, spring will retract the stem.

Thrust models provide more force, but less travel than lever models. Refer to Tables 1 and 5.

Lever Model

This model has direct or reverse action with a direct acting spring. The lever is steel with eight 0.375 inch (9.525mm) diameter holes and is 0.5 inches (34.9mm) wide by 23.75 inches (603.2mm) long. Needle bearings are used at critical pivot holes in the lever. Either direct or reverse action is possible on the lever model by reversing the lever.

Lever models provide more travel, but less force than the thrust models. Refer to Tables 1 through 5.

Options

Positioners

Actuators can be equipped with a single-acting, side-mounted valve positioner of either pneumatic or electro pneumatic type..

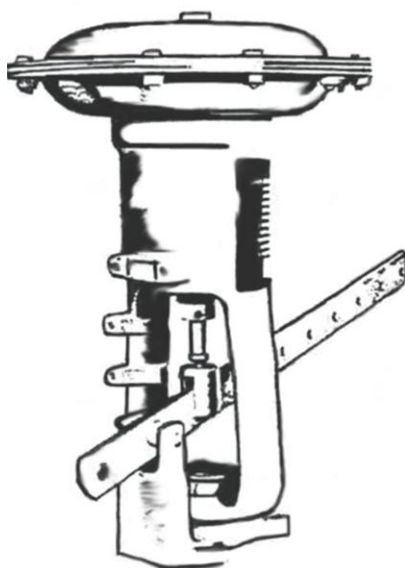

Figure 1 - Lever Model

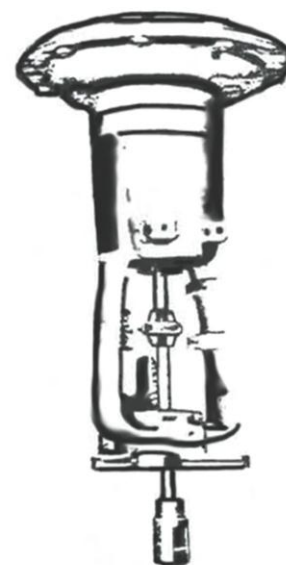

Figure 2 - Thrust Model

Table 1 - Travel, Thrust Models,

Action	Direct or Reverse		
Actuator Size	01-9	01-11	01-13
Travel, Inches (millimeters)	1.125 (27.575)	1.50 (38.1)	1.50 (38.1)

Table 2 - Travel Lever Models, Direct or Reverse Action

Actuator Size		01-9	01-11	01-13
Air-Motor Model	Lever Hole	Travel Inches (millimeters)		
	A	2.42 (61.46)	3.24 (82.29)	3.24 (82.29)
	B	3.22 (81.78)	4.32 (109.72)	4.32 (109.72)
	C	4.03 (102.36)	5.40 (137.16)	5.40 (137.16)
	D	4.83 (122.68)	6.48 (164.59)	6.48 (164.59)
	E	5.65 (143.51)	7.57 (192.27)	7.57 (192.27)
	F	6.45 (163.83)	8.63 (219.20)	8.63 (219.20)
	G	7.26 (184.4)	9.72 (246.88)	9.72 (246.88)
	H	8.08 (205.2)	10.80 (274.32)	10.80 (274.32)

TABLE 3 - Forces Springless Air-O-Motor Actuators				
Actuator Size		01-9	01-11	01-13
Actuator Model	Lever Hole	Force, Lbs.		
Thrust	-	660	980	1350
Lever	A	305	455	625
	B	230	340	470
	C	180	270	375
	D	150	225	310
	E	130	195	260
	F	110	170	235
	G	100	150	210
	H	90	135	190

The thrusts are based upon a supply pressure of 18 psig (124.1kPa) and a constant loading pressure of 3 psig (20.68 kPa), which results in a differential or overpressure of 15 psig (34.4k kPa), divided the listed values by 15 and then multiply by the actual differential or overpressure.

TABLE 4 - Force (lbs) for Lever Model (Direct or Reverse)																					
Full Travel												Zero Travel									
Actuator Size	01-9				01-11				01-13				01-9		01-11		01-13				
Spring	3-15		6-30		3-15		6-30		3-15		6-30		3-15	6-30	3-15	6-30	3-15	6-30			
Air Pressure	18	35	50	35	50	18	35	50	35	50	18	35	50	35	50	-	-	-	-	-	-
Lever Hole	Forces, lbs										Force, lbs										
A	60	405	720	100	405	90	605	1050	150	605	125	835	1450	205	835	66	132	100	200	155	310
B	45	305	540	75	305	65	455	795	115	455	94	625	1100	155	625	49	98	75	150	115	230
C	36	245	430	60	245	55	360	635	90	360	75	500	875	125	500	39	78	60	120	95	190
D	30	200	355	50	200	45	300	530	75	300	62	415	725	105	415	33	66	50	100	78	156
E	26	170	305	43	170	38	260	450	65	260	53	355	625	90	355	28	56	42	84	67	134
F	23	150	265	38	150	34	225	395	55	225	47	310	550	75	310	25	50	37	74	59	118
G	20	135	235	34	135	30	200	350	50	200	41	275	485	70	275	22	44	33	66	52	104
H	16	120	215	30	120	27	180	135	45	180	37	250	435	62	250	20	40	30	60	47	94

TABLE 5 - Force (lbs) for Thrust Model																					
Full Travel												Zero Travel									
Actuator Size	01-9				01-11				01-13				01-9		01-11		01-13				
Spring Range	3-15		6-30		3-15		6-30		3-15		6-30		3-15	6-30	3-15	6-30	3-15	6-30			
Air Pressure	18	35	50	35	50	18	35	50	35	50	18	35	50	35	50	-	-	-	-	-	-
Force Lbs	130	880	1550	220	880	145	1310	2290	325	1310	270	1800	3150	450	1800	140	280	215	430	335	670

TABLE 6 - Wall Bracket Dimensions (Figure 3)						
Actuator Size	Dimensions, Inches (Millimeters)					
	A	B	C	D	E	F
9	5.5 (139.70)	7.56 (192.02)	5.0 (127.0)	0.56 (14.22)	3.0 (76.20)	1.50 (38.10)
11	7.75 (196.85)	8.06 (204.72)	5.0 (127.0)	1.0 (25.4)	3.0 (76.20)	1.50 (38.10)
13	7.75 (196.85)	8.06 (204.72)	5.0 (127.0)	1.0 (25.4)	3.0 (76.20)	1.50 (38.10)

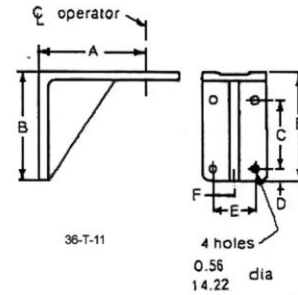

Figure 3 - Wall Bracket Dimensions (Refer to Table 6)

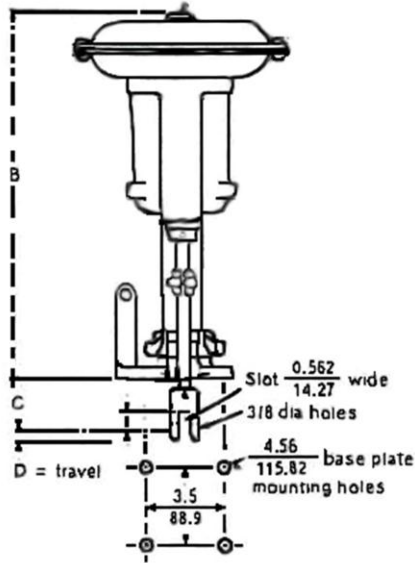

Figure 4 - Thrust Model (refer to Table 7)

TABLE 7 - Dimensions, Inches (Millimeters), Thrust Models (Figure 4 and 5)					
Actuator Size	B				
	A	Direct	C*	D	E
9	10.50 (266.70)	17.12 (434.84)	2.43 (61.72)	1.12 (28.44)	5.62 (142.74)
11	12.75 (323.85)	18.50 (469.90)	2.43 (61.72)	1.50 (38.10)	5.93 (160.62)
13	15.0 (381.0)	21.0 (533.40)	2.75 (69.85)	1.50 (38.10)	7.25 (184.15)

* At beginning of stroke for direct actuators; at end of stroke for reverse actuators

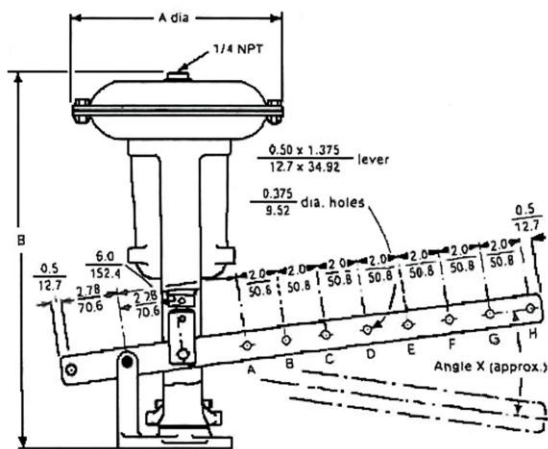

Figure 6 - Lever Model (Refer to Table 8)

TABLE 8 - Dimensions, Inches (Millimeters) Lever Models (Figure 6)

A	B	Angle X
10.50 (266.70)	17.12 (434.84)	23°
12.75 (323.85)	18.50 (469.90)	31°
15.0 (381.0)	21.0 (533.40)	31°

Specification	
Operating Conditions	
Ambient Temperature Range (Buna-N Nylon diaphragm*)	-40° to 82°C (-40° to 180°F)
Performance	
Travel	Refer to tables 1 and 2
Force	Refer to tables 3, 4 and 5
Spring Ranges	Refer to Tables 4 and 5
Design	
Air Supply	Maximum air pressure to all actuator diaphragms is 50 psig (344.7 kPa). All air connections are 1/4 inch NPT
Mounting	Both models, lever and thrust, are constructed for base mounting. A right angle bracket kit can be supplied if wall or vertical mounting is required.
Dimensions	Wall Bracket - Refer to Table 6 (Figure 3) Thrust Model - Refer to Table 7 (Figures 4 and 5) Lever Model - Refer to Table 8 (Figure 6)

* Other diaphragm materials are available for higher or lower temperatures

Ordering Information

Instructions	<ul style="list-style-type: none"> · Select the Key Number · Make one Selection each from Tables I Through III · Select the proper number of digits in each table <p>Key Number I II III</p> <p>_____ - ____ - ____ - ____</p>
---------------------	--

Selection

Key Number	Size		
	9.....	861M1	↓
	11.....	861P1	↓
	13.....	861R1	↓

Table I Model Spring Range	Model	Spring Range		
Lever		3-15	A	·
		6-30	B	·
Thrust		3-15	F	·
		6-30	G	·

Table II Actuator Configuration			
	Plain.....	1	·
	Top Mounted Handwheel.....	2	·

Table III Mounting			
	Base Mounting.....	1	·
	Wall Mounting.....	2	·

Please specify:

All required accessories

Specifications are subject to change without notice.