

Instruction  
SP-8100-1NE  
December 2010

# NOR'EAST

— CONTROLS, INC.

A DIVISION OF ALLGASH INTERNATIONAL, INC.



## Spare Parts

**SERIES 8100 SINGLE SEATED,  
CAGE TYPE GLOBE VALVES**

Previously manufactured by Dezurik® and Honeywell®

# Nor' East

## 2-1/2" - 6" Series 8100 Cage Valves

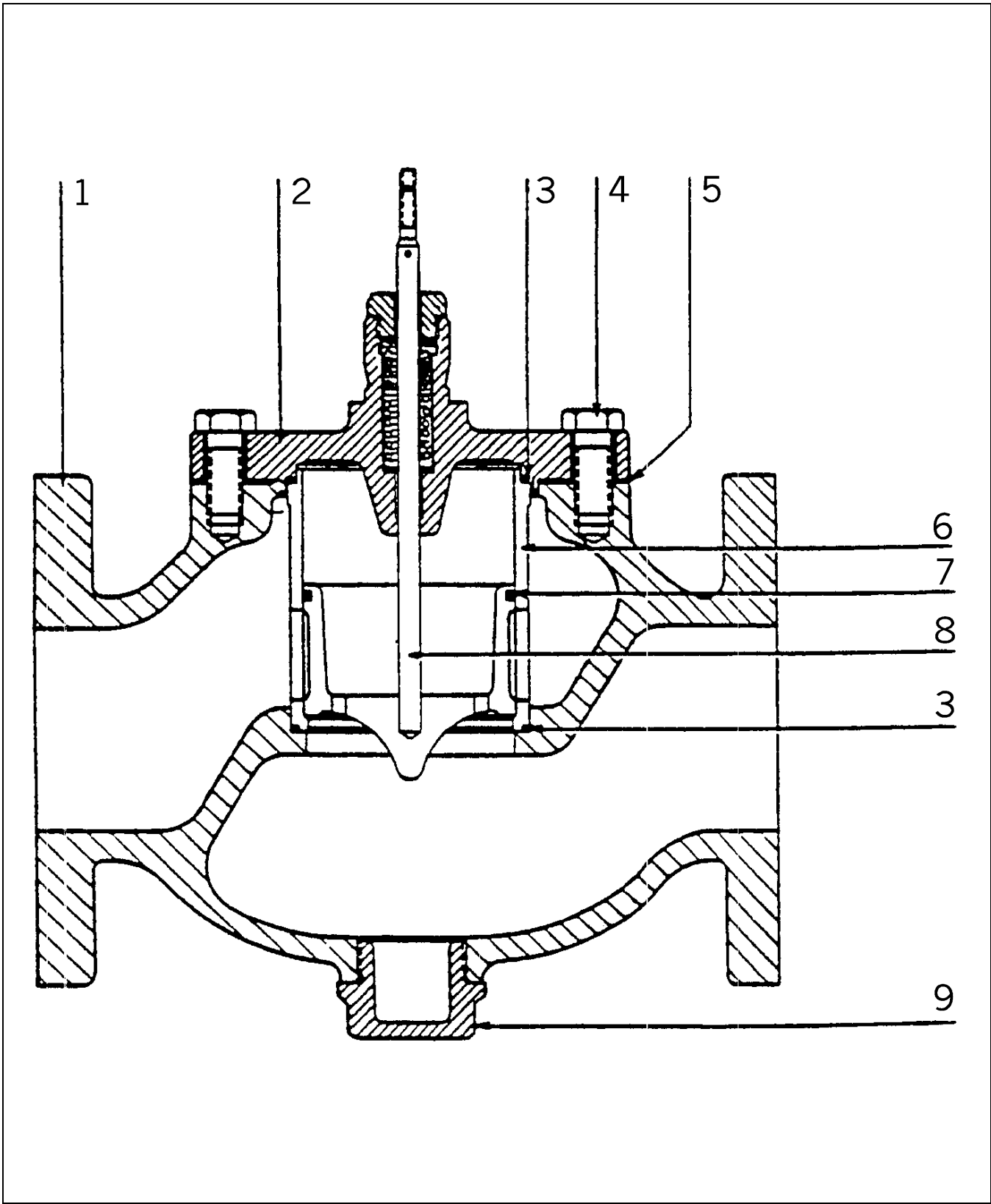

Figure 1 - 2-1/2" - 6" Valves

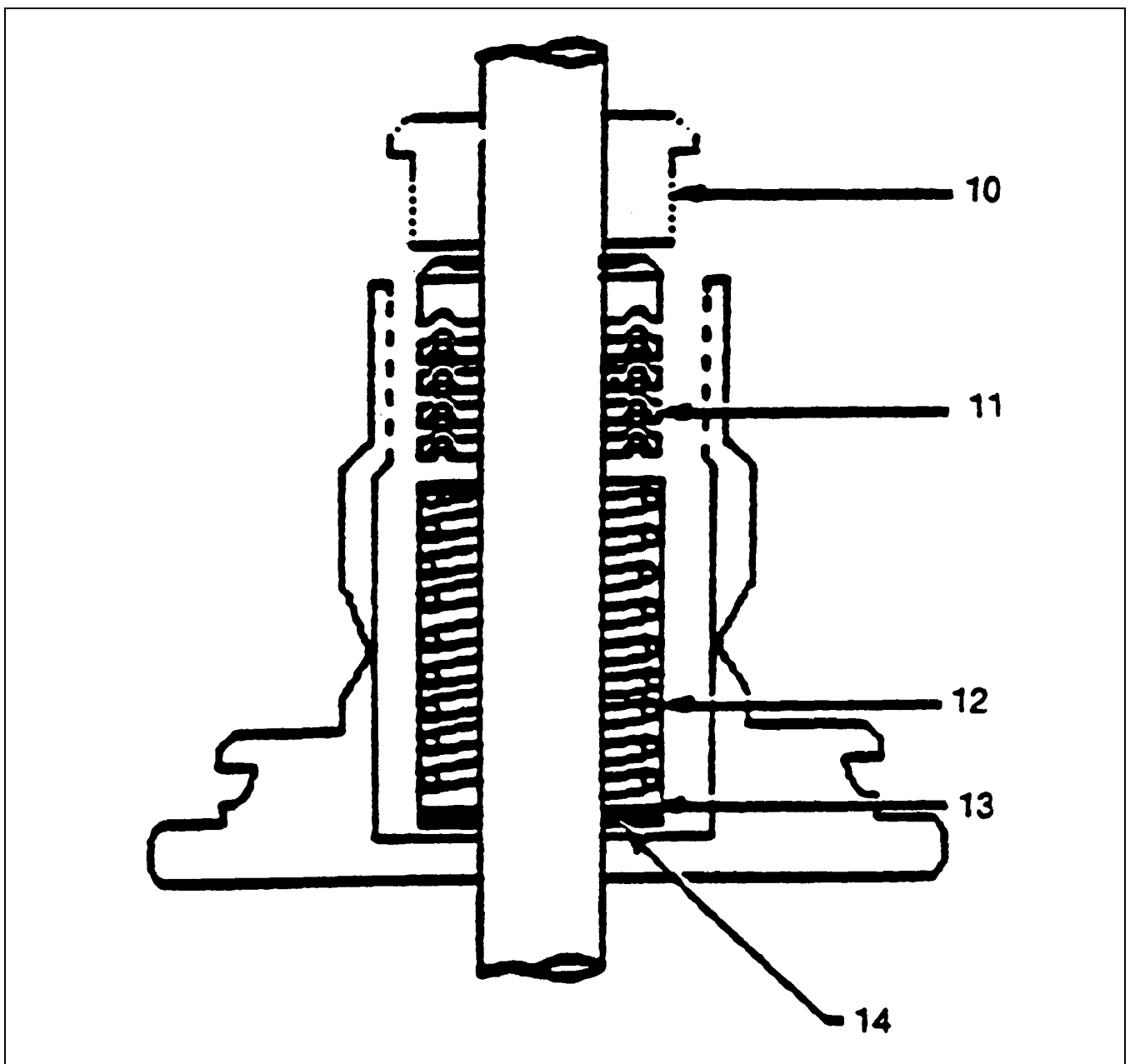

Figure 2 – Teflon V-Ring Packing

# Nor' East

## 2-1/2" – 6" 8100 Series Single Seated Cage Valves

---

### Key No. 1 – Body, Cast Iron

Rating	Valve Size				
	2-1/2"	3"	4"	5"	6"
125 lb.	30672396-001	30672400-001	30672405-001	30672039-001	30672408-001
250 lb.	30680904-001	30680905-001	30680906-001	30680907-001	30680908-001

### Key No. 2 – Bonnet

Valve Size				
2-1/2"	3"	4"	5"	6"
30672018-001	30672024-001	30672029-001	30672034-001	30672040-001

### Key No. 3 – Cage O-rings

Valve Size			
2-1/2"	3"	4"	5" & 6"
30067529-891	30067531-001	30067533-001	30067535-001
Qty 2	Qty 2	Qty 2	Qty 2

### Key No. 4 – Cap Screws

Valve Size			
2-1/2"	3"	4" & 5"	6"
30008504-264	30007815-264	30041083-264	30041094-264
Qty 4	Qty 6	Qty 6	Qty 8

### Key No. 5 – Bonnet Gasket

Valve Size				
2-1/2"	3"	4"	5"	6"
30046304-859	30046335-859	30046366-859	30672049-001	30046541-859

### 8100 Packing Kit

Valve Size
2-1/2" – 6"
30775677-001
Kit includes: Packing box nut, v-ring packing, spring, washer & o-ring

**8100 Gasket Kit**

Valve Size				
2-1/2"	3"	4"	5"	6"
30775511-001	30775512-001	30775513-001	30775546-001	30776360-001
Gasket kit includes: one bonnet gasket, two cage o-rings, one spring seal and one container of lubricant				

**Key No. 6 - Cage**

Trim Material	Valve Size			
	2-1/2"		3"	
	LVP	%VP	LVP	%VP
S.S.	30672022-002	30672023-002	30672027-002	30672028-002
Bronze	30672022-001	30672023-001	30672027-001	30672028-001
Trim Material	4"		5 & 6"	
	LVP	%VP	LVP	%VP
	S.S.	30672032-002	30672033-002	30672037-002
Bronze	30672032-001	30672033-001	30672038-001	30672088-001

**Key No. 7 – Spring Seal**

Valve Size			
2-1/2"	3"	4"	5" & 6"
30775505-001	30775505-002	30775505-003	30775505-004

**Key No. 8 – Plug and Stem Subassembly**

Trim Material	Valve Size			
	2-1/2"	3"	4"	5 & 6"
S.S.	30672019-002	30672025-002	30672030-002	30672035-002
Bronze	30672019-001	30672025-001	30672030-001	30672035-001

**Key No. 9 – Cap**

30041026-200
--------------

**Key No. 10 – Packing Box Nut**

30745181-001
--------------

**Key No. 11 – V-Ring Packing**

30065395-936	Lubricate inner and outer diameter lightly before assembly.
--------------	---

**Key No. 12 – Spring**

30041084-218
--------------

**Key No. 13 – Washer**

30078905-000
--------------

**Key No. 14 – O-Ring**

30685440-026	Lubricate inner and outer diameter lightly before assembly.
--------------	---

# Nor' East

## 2-1/2" – 6" 8100 Series Single Seated Cage Valves

---

### Guarantee

Products, auxiliaries and parts thereof, of Nor'East Controls' manufacture, are guaranteed for a period of one year from the date of shipment against defective workmanship and material only, when properly installed, operated and serviced in accordance with Nor'East Controls' recommendations. Replacement for items of Nor'East Controls' manufacture will be made free of charge if proved to be defective within such time. No claim for special or consequential damages, transportation, or labor shall be allowed. Purchaser shall be solely responsible for determining suitability for use and in no event shall Nor'East Controls be liable in this respect. Equipment or parts manufactured by others but furnished by Nor'East Controls will be repaired or replaced, only to the extent provided in the original manufacturer's warranty to Nor'East Controls. Nor'East Controls does not guarantee resistance to corrosion, erosion, abrasion or other sources of failure, nor does Nor'East Controls guarantee a minimum length of service. Failure of the purchaser to give prompt written notice of any alleged defect under this guarantee forthwith upon its discovery, or use and possession thereof after an attempt has been made and completed by someone other than Nor'East Controls or an authorized representative to remedy defects therein, or failure to return products or parts for replacement as herein provided, of failure to install, operate, and maintain said products or parts according to instructions provided by Nor'East Controls, of failure to pay the entire contract price when due, shall be a waiver of all rights under these representations.

The foregoing guarantee shall be null and void, if, after shipment from our factory, the item is modified in any way or component of another manufacturer, such as but not limited to; an actuator is attached to the item by valves & controls other than a Nor'East Controls

Factory Service Personnel. All orders accepted shall be deemed accepted subject to this guarantee, which shall be exclusive of any other previous guarantee, and this shall be the only effective guarantee or warranty binding on Nor'East Controls, anything to the contrary contained in the purchase order, or represented by any agent or employee of Nor'East Controls, in writing or otherwise, notwithstanding, including but not limited to implied warranties.

THE FOREGOING OBLIGATIONS ARE IN LIEU OF ALL OTHER OBLIGATIONS AND LIABILITIES INCLUDING WARRANTIES OF FITNESS OR MERCHANTABILITY OR OTHERWISE, EXPRESSED OR IMPLIED IN FACT OR BY LAW, AND STATE NOR'EAST CONTROLS AND EXCLUSIVE LIABILITY AND PURCHASER'S EXCLUSIVE REMEDY FOR ANY CLAIM IN CONNECTION WITH THIS SALE OR FURNISHING OF SERVICES, GOODS, OR PARTS, THEIR OWN DESIGN, SUITABILITY FOR USE, INSTALLATION OR OPERATION.

### Limitation of Liability

In no event shall Nor'East Controls be liable for any direct, indirect, special or consequential damages whatsoever, and Nor'East Controls' liability, under no circumstances, will exceed the contract price for the goods and/or services for which liability is claimed. Any action for breach of contract must be commenced within 1 year after the cause of the action has occurred.

1000 Riverside Street, Portland, Maine 04103

Ph: 207-781-8831 Fax: 207-781-8830

### Sales and Service

Nor' East Controls representatives are located in major cities throughout the world.

For the name of the representative nearest you, contact:

**Web site:** [www.allagashinternational.com](http://www.allagashinternational.com)    **E-Mail:** [sales@allagashinternational.com](mailto:sales@allagashinternational.com)

Nor' East reserves the right to incorporate our latest design and material changes without notice or obligation. Design features, materials of construction and dimensional data, as described in this bulletin, are provided for your information only and should not be relied upon unless confirmed in writing by Nor' East Controls. Certified drawings are available upon request.